

OPTIMIZE NOZZLE LOCATION FOR MINIMIZATION OF STRESSES IN PRESSURE VESSEL

(Optimize angle and location of nozzle for minimization stress without
reinforcement)

Shyam R. Gupta¹, Ashish Desai², Chetan P. Vora³

¹*Mechanical engineering, Kalol Institute of Technology & Research Centre, shyam.gupta1789@gmail.com*

²*Mechanical engineering, LDRP engineering college, desaiashish1@gmail.com*

³*Mechanical engineering, Kalol Institute of Technology & Research Centre, vorachetan1@gmail.com*

Abstract: Pressure vessels are leak proof containers. These are having wide range of applications in several fabrication industries like steel plants in addition to the main equipment like blast furnace, Nozzles or openings are necessary in the pressure vessels to satisfy certain requirements such as inlet or outlet connections, manholes, vents and drains etc. To incorporate a nozzle on the vessel wall it is supposed to remove some amount of material from the vessel. Then the stress distribution is not uniform. Distribution of stress in the juncture area and the rest will differ as nozzles cause a geometric discontinuity of the vessel wall. So a stress concentration is created around the opening. The junction may fail due to these high stresses. In the present work, the importance of the effect of the discontinuity is mentioned, codes related to design of vessels and its components is discussed; nozzle and vessel parameters are calculated using ASME code formulae. PV Elite is used to determine the design of pressure vessel like the thickness of shell and nozzle data. Different nozzle location without reinforcement of nozzle for offset of 0, 8, 16, 24 and 32 inch from vertical centre line at central cross section with different inclination angles like 0°, 15°, 30° and 45° are modeled with Creo Parametric 2.0. ANSYS workbench is used to analyze the model made in Creo Parametric 2.0 by importing it in the workbench environment, generating proper meshing, and applying boundary condition. Von-mises stress and deformation are plotted for all options under study. At initial stage all options are evaluated without reinforcement. Summary of all Von-Mises plot are presented in tabulated as well as graphical form. Conclusions are made by discussing from available results. Future scope of work is mentioned clearly from current work for further study

Key word: horizontal pressure vessel, PVELite software, Creo parametric 2.0, ANSYS, von-mises stress, nozzle angle and nozzle offset, radial and hill-side nozzle. Finite Element Method, Reinforcement Pad, ASME code section VIII division I.

I. INTRODUCTION

A pressure vessel is a closed container designed to hold gases or liquids at a pressure substantially different from the ambient pressure. The pressure differential is dangerous and many fatal accidents have occurred in the history of pressure vessel development and operation. Consequently, pressure vessel design, manufacture, and operation are regulated by engineering authorities backed by legislation. In general, Pressure vessels are design with ASME Boiler and Pressure Vessel Code, Section VIII., Division 1 and do not require a detailed evaluation of all stresses. They are used in a wide variety of industries (e.g., petroleum refining, chemical, power, pulp and paper, food, etc.) Examples of pressure systems and equipment are\ boilers and steam heating systems; pressurized process plant and piping; compressed air systems (fixed and portable); pressure cookers, autoclaves and retorts; heat exchangers

and refrigeration plant; valves, steam traps and filters; pipe work and hoses; and Pressure gauges and level indicators.

II. BRIEF OVERVIEW OF SOME RESEARCH:

As there are lot of work is done on the pressure vessels. A brief review of some selected references.

A. M Javed Hyder, et al, presented work to optimize location and size of opening in pressure vessel cylinder using ANSYS, Analysis performed for three thick-walled cylinders with internal diameter 20, 25 and 30 cm having 30 cm height and wall thickness of 20 mm. first they done analysis of pressure vessel cylinder without hole, they found tangential, longitudinal, radial, and von misses stress ,then optimization of hole size is carried out by making hole having diameter of 4,8,10,12,14,16 and 20 mm located at center in each of three thick cylinders, from fig 14 they found that the optimum size of hole is 8 mm cylinder having internal diameter 20 cm and hole size 10 mm for cylinder having internal diameter of 25 cm and 30 cm has lowest von Misses stress value and finally 12 mm hole located at 1/6, 1/8, 2/8, 3/8, and 4/8 of cylinder from top in all three cylinders, and they found Von Misses stress is maximum at the center 0.500 location and decreased directed away from the center and the stress increased at the location change from 0.1250 to 0.0625 from cylinder top due to end effect and finally they found Von-Mises stress is minimum at location 1/8 of cylinder height.

B. Jorger.R Miranda, et al had presented their work on stress analysis on vessel/nozzle intersection with/without pad reinforcement for cylindrical pressure, the objective of is that to evaluate the stress field on the vessel/nozzle intersection of cylindrical pressure vessel using more realistic finite element model, here three model was developed concerning the vessel /nozzle intersection these are (1) unreinforced vessel/nozzle intersection (2) bonded pad reinforced vessel/nozzle intersection (pad is integrally welded on the vessel/nozzle intersection) and (3) partially welded pad reinforced vessel/nozzle intersection (border of the pad are considered bonded simulating welding line and friction contact hypothesis is assumed in the pad/vessel contact surface), pad was designed by ASME code with area replacing method criteria, ANSYS workbench finite element tool was used for develop this model with 20-node high solid element, linear and non-linear elastic analysis performed and result obtained with experimental which was done in previous one paper of literature and compared with ANSYS software work. on phase I, non-reinforced vessel model was compared with experimental data from one of paper of previous work, then model of bonded pad and partially welded were then analyzed and result was compared with experimental work ,and from these they got result tangential and radial peak stress were significantly reduced at intersection of nozzle/shell and in other side partially welded pad reinforced model present tangential stresses 20% higher and radial stresses were significantly higher than bonded pad reinforced model.

C. Binesh P Vyas, et al concluded that Design of pressure vessel by using PVElite gives accurate analysis result and also reduces time .A vertical pressure vessel has been designed using graphical based software named PVElite. For designing of vertical leg supported pressure vessel some input parameters like volume, inside diameter, design pressure (either inside pressure or external pressure), temperature, material, processing fluid. Etc. is required. PVElite gives thickness of shell, thickness of head, height of head, thickness of nozzle, manhole, PVElite calculate local stress according to welding research council (WRC) 107, further research need to explore environmental parameter such as earthquake, thermal load, fluctuation load and so on.

III. DESIGN DATA OF PRESSURE VESSEL:

Pressure Vessel Details of PVElite:

Pressure for Nozzle Reinforcement Calculation	439.000 psig
Temperature for Internal Pressure	122 F
Shell Material	SA-516 70

Inside Diameter of Cylindrical Shell	84.0000 in.
Shell Actual Thickness	1.0000 in.
Shell Internal Corrosion Allowance	0.0000 in.
Shell External Corrosion Allowance	0.0000 in.

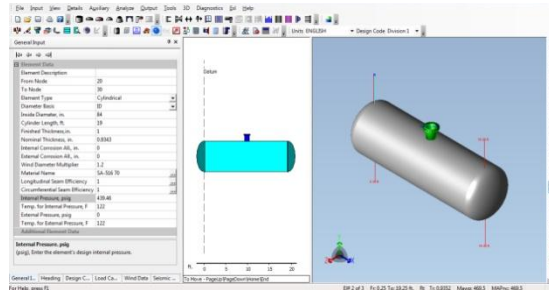

Figure 1 pressure vessel model at 0 degree at 0 offset

Nozzle Material	SA-516 70
Nozzle Diameter Basis	ID
Layout Angle	0.00 deg
Nozzle Diameter	16.0000 in.
Nozzle Size and Thickness Basis	Nominal
Nominal Thickness of Nozzle	100
Nozzle Flange Material	SA-516 70
Nozzle Flange Type	Weld Neck Flange
Nozzle Corrosion Allowance	0.0000 in.
Joint Efficiency of Shell Seam at Nozzle	1.00
Joint Efficiency of Nozzle Neck	1.00
Nozzle Outside Projection	12.0000 in.
Weld leg size between Nozzle and Pad/Shell	0.7500 in.
Groove weld depth between Nozzle and Vessel	0.5000 in.
Pad Material	SA-516 70
Diameter of Pad along vessel surface	24.0000 in.
Thickness of Pad	2.0000 in.
Weld leg size between Pad and Shell	0.7500 in.
Groove weld depth between Pad and Nozzle	0.7500 in.
Reinforcing Pad Width	4.0000 in.
Class of attached Flange	300
Grade of attached Flange	GR 1.2

The design of this vessel and its components is done using ASME SEC. VIII Div I code. Principal dimensions of the pipe flange and flange fittings are taken from ASME B 16.5 Standard. For specifying nozzle thickness ANSI pipe schedule is used. This is the details of 0 degree and 0 offset nozzle from centre, the others type of pressure vessel at 0 inch offset and at 15 degree, 30 degree and 45 degree of nozzle are design by using PVELite software. Same way for 8 inch offset, 16 inch offset, 24 inch offset and 32 inch offset of nozzle from centre at various inclination angles are designed by using this software.

IV. PVELITE SOFTWARE OUTPUT

A. Cylindrical Shell (Ug-27):

Thickness of shell Due to Internal Pressure:

$$\begin{aligned} &= (P*(D/2+CA)) / (S*E-0.6*P) \text{ per UG-27 (c)(1)} \\ &= (439.46*(84.0000/2+0.0000))/(23400.00*1.00-0.6*439.46) \\ &= 0.9352 + 0.0000 = 0.9352 \text{ in.} \end{aligned}$$

B. Elliptical Head (Ug-32):

Thickness of Elliptical Head Due to Internal Pressure:

$$\begin{aligned} &= (P*(D/2*CA)*K) / (2*S*E-0.2*P) \text{ Appendix 1-4(c)} \\ &= (439.46*(84.0000/2*0.0)*1.00)/(2*23400*1.000.2*439.46) \\ &= 0.9249 + 0.0000 = 0.9249 \text{ in.} \end{aligned}$$

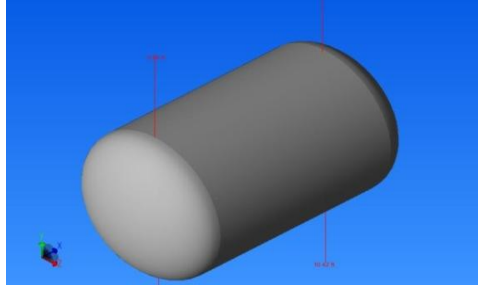

Figure 2 Elliptical head with cylindrical shell

V. FINITE ELEMENT MODELING AND ANALYSIS OF PRESSURE VESSEL:

A. PRE-PROCESSING

Pre-processing comprises of building, meshing and loading the model created.

Define type of Analysis.

ANSYS work bench provide wide verity of analysis for real life problem for mechanical and other engineering problems. Static Structural analysis is used for solving current problem.

Define Engineering Data for Analysis.

The material that is considered for the shell as well as nozzle is SA 516 GRADE 70; it is having mechanical properties like young's modulus of 2.0e5 Mpa and poison's ratio of 0.29.

Define or import 3D model.

Pressure vessel models of different condition are modeled with application of PRO-Engineer. The models are exported as STEP file with solid as option. Same models are imported into ANSYS Workbench Environment.

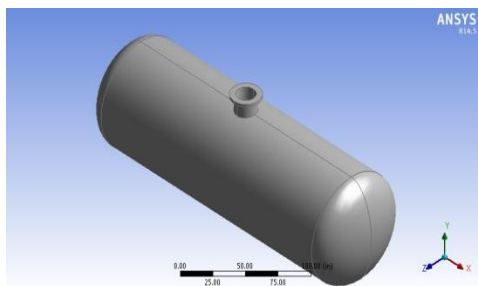

Figure 3 Pressure vessel model

Define Boundary Condition for Analysis.

All the degrees of freedom of the pressure vessel are arrested at the right side edges at shell and head joint location for all models of pressure vessel under study throughout the work.

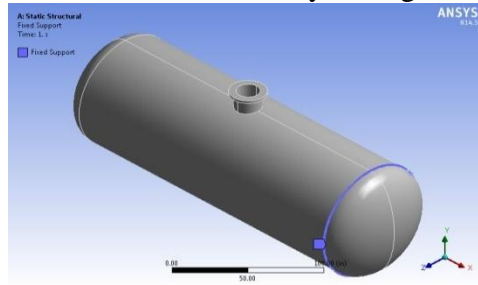

Figure 4 Pressure vessel model with fixed boundary

The magnitude of the pressure considered for the nozzle is **439.46** Psi at all internal faces.

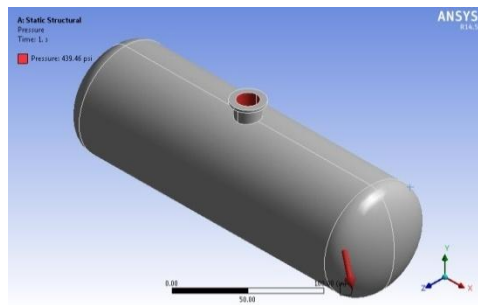

Figure 5 Pressure vessel model with pressure load condition

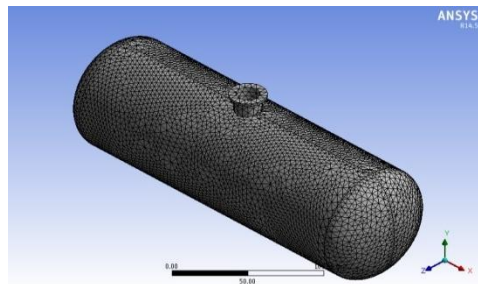

Figure 6 Meshed model of Pressure vessel

Mesh Statics:

Type of Element	: Tetrahedrons
Number of Nodes	: 76612
Number of Elements	: 38346

ANSYS offers a complete set of tools for automatic mesh generation, including mapped mesh generation and free mesh generation. Both mapped meshing and free meshing can access geometric information in the form of point, curves and surfaces. The model is meshed with 10-noded tetrahedral (Tet-10) solid elements.

B. SOLVING THE MODEL:

With all parts of the model defined, nodes, element, restraints and loads, the analysis part of the model is ready to begin. The system can determine approximately the values of stresses, deflection, temperature, pressure and vibration.

- ✓ An analysis requires the following information:
- ✓ Nodal point
- ✓ Element connecting the nodal points
- ✓ Material and its physical properties
- ✓ Boundary conditions, which consists of loads and constraints
- ✓ Analysis options: how the problem will be evaluated

C. POST-PROCESSING:

The post-processing task displays and studies the result of an analysis, which exists in the model as analysis data sets. This task can generate displays of stress contours, deformed geometry, etc.

ASSUMPTIONS FOR FINITE ELEMENT ANALYSIS OF PRESSURE VESSEL:

- Analysis type taken is static structural while neglecting effect of loading and boundary condition with time.
- Model is simplified as no saddle support is considered while modelling the pressure vessel.
- Both Shell and Head thickness is approximated and considered as 1 inch.
- The model is considered with single vertical outlet nozzle vertically at centre of cross section of vessel at centre of shell.
- Vertical nozzle at centre considered as reference condition with 0 inch offset distance and as base condition 0° inclination with vertical centre line.
- Only internal pressure is consider as load while neglecting all External loads.
- One side shell to head joining edges is considered as fixed boundary condition.

VI. PRESSURE VESSEL WITH NOZZLE AT 0 INCH OFFSET FROM CENTRE:

The model is considered with single vertical nozzle which is at centre so offset distance is 0 inch and also initially as base condition inclination is also 0° . While exploring other design offset is considered from centre of cress section at centre of shell and vertical line is considered as reference for inclination.

A. FEA OF PRESSURE VESSEL WITH NOZZLE AT 0 INCH OFFSET AT 0 DEGREE INCLINATIONS:

Structural analysis of Pressure vessel with nozzle at 0 inch offset at 0 degree inclination is carrier out with 3D solid model shown in figure 7 to evaluate and compare the results with other option of inclination. Structural boundary conditions and loading are kept same as reference condition.

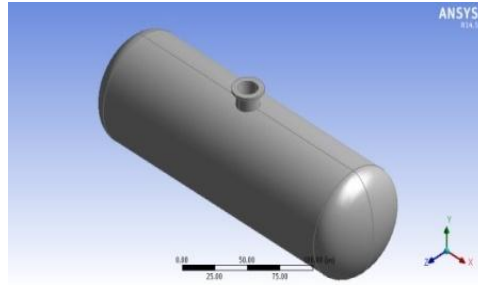

Figure 7 Pressure vessel model with nozzle at 0 inch offset at 0 degree inclination.

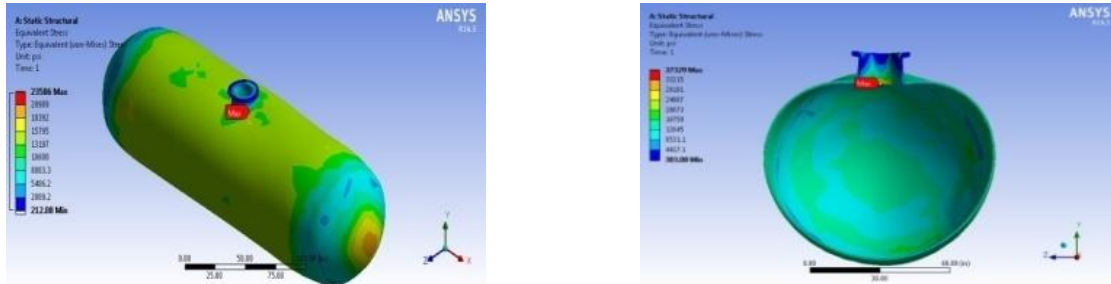

Figure 8 Stress profile of Pressure vessel with nozzle at 0 inch offset at 0 degree inclination.

Result summary

Maximum stress on nozzle: 23586 Psi
 Minimum stress on vessel: 212.08 psi
 Maximum deformation on vessel: 0.099313 inch

B. FEA RESULT SUMMARY OF PRESSURE VESSEL WITH NOZZLE AT 0 INCH OFFSET with VARIOUS INCLINATION ANGLES :

Table 1 Result summary of Pressure vessel with nozzle at 0 inch offset

Inclination angle (degree)	Stress (psi)		Deformation (inch)	
	max	min	max	min
0	23586	212.08	0.099313	0
15	26263	560.55	0.099418	0
30	28644	422	0.099726	0
45	24308	384.02	0.099556	0

Structural analysis of Pressure vessel with nozzle at 0 inch offset at 0 degree inclination is carried out with 3D solid model shown in figure 7 and figure 8, now same way another structural analysis of pressure vessel with nozzle at 0 inch offset and different inclination angle of 15°, 30° and 45° modelled and analysed for same pressure loading and boundary conditions, and we have result shown in above table. And graph shown in figure 9 which is stress Vs inclination angle.

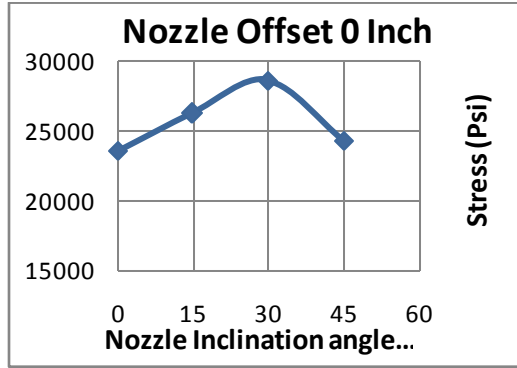

Figure 9 Von-mises Stress plot of Pressure vessel with nozzle at 0 inch offset.

VII. PRESSURE VESSEL WITH NOZZLE AT 8 INCH OFFSET FROM CENTRE:

The model is considered with single vertical nozzle which is at centre so offset distance is 8 inches and also initially as base condition inclination is also 0°.

A. FEA RESULT SUMMARY OF PRESSURE VESSEL WITH NOZZLE AT 8 INCH OFFSET WITH VARIOUS INCLINATION ANGLES :

Now structural analysis of pressure vessel with nozzle at 8 inch offset and different inclination angle of 0°, 15°, 30° and 45° modelled and analysed for same pressure loading and boundary conditions, and we have result shown in below graph and table,

Table 2 Result summary of Pressure vessel with nozzle at 8 inch offset.

Inclination Angle	Stress(Psi)		Deformation	
	Maxi	Min	Max	Min
0	27243	369.78	0.0996	0
15	23829	310.89	0.09982	0
30	21686	216.67	0.1005	0
45	23244	157.94	0.099622	0

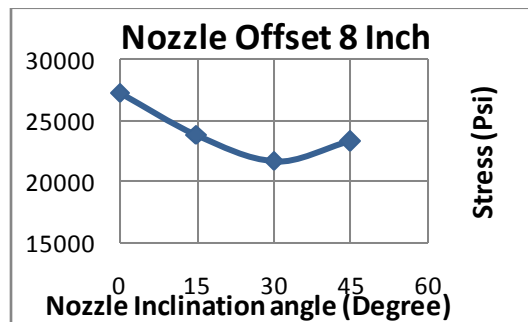

Figure 10 Von-mises Stress plot of Pressure vessel with nozzle at 8 inch offset

VIII. PRESSURE VESSEL WITH NOZZLE AT 16 INCH OFFSET FROM CENTRE:

The model is considered with single vertical nozzle which is at centre so offset distance is 16 inches and also initially as base condition inclination is also 0°

**A. FEA RESULT SUMMARY OF PRESSURE VESSEL WITH NOZZLE AT 16 INCH OFFSET
WITH VARIOUS INCLINATION ANGLES:**

Now structural analysis of pressure vessel with nozzle at 16 inch offset and different inclination angle of 0°, 15°, 30° and 45° modelled and analysed for same pressure loading and boundary conditions, and we have result shown in below graph and table,

Table 3 result summary of pressure vessel with 16 inch offset

Inclination angle	Stress (psi)		deformation	
	Max,	Min.	Max.	Min.
0	22132	212.58	0.10014	0
15	23042	258.59	0.1005	0
30	22745	348.05	0.099617	0
45	23320	222.82	0.09927	0

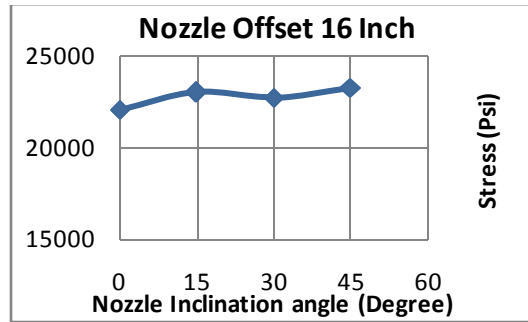

Figure 11 Von-misses Stress plot of Pressure vessel with nozzle at 16 inch offset.

IX. PRESSURE VESSEL WITH NOZZLE AT 24 INCH OFFSET FROM CENTRE:

The model is considered with single vertical nozzle which is at centre so offset distance is 24 inches and also initially as base condition inclination is also 0°.

A. FEA RESULT SUMMARY OF PRESSURE VESSEL WITH NOZZLE AT 24 INCH OFFSET WITH VARIOUS INCLINATION ANGLES:

Now structural analysis of pressure vessel with nozzle at 24 inch offset and different inclination angle of 0°, 15°, 30° and 45° modelled and analysed for same pressure loading and boundary conditions, and we have result shown in below graph and table,

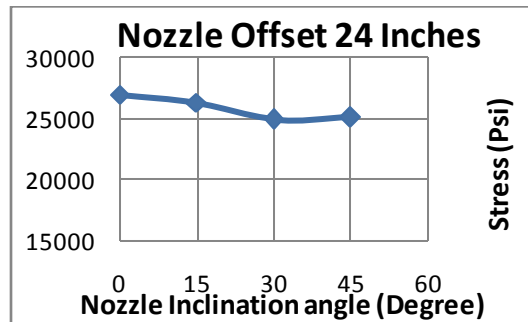

Figure 12 Von-misses Stress plot of Pressure vessel with nozzle at 24 inch offset

Table 4 Result summary of Pressure vessel with nozzle at 24 inch offset.

Inclination angle (degree)	Stress (psi)		Deformation (inch)	
	max	min	max	min
0	26931	222.1	0.1003	0
15	26333	219.35	0.1002	0
30	24904	128.29	0.099015	0
45	25056	73.719	0.098619	0

X. PRESSURE VESSEL WITH NOZZLE AT 32 INCH OFFSET FROM CENTRE

The model is considered with single vertical nozzle which is at centre so offset distance is 32 inches and also initially as base condition inclination is also 0°.

A. FEA RESULT SUMMARY OF PRESSURE VESSEL WITH NOZZLE AT 32 INCH OFFSET WITH VARIOUS INCLINATION ANGLES:

Now structural analysis of pressure vessel with nozzle at 32 inch offset and different inclination angle of 0°, 15°, 30° and 45° modelled and analysed for same pressure loading and boundary conditions, and we have result shown in below table.

Table 5 Result summary of Pressure vessel with nozzle at 32 inch offset.

Inclination angle	Stress(psi)		deformation	
	Max.	Min.	Max.	Min.
0	18645	164.98	0.068283	0
15	21107	260.37	0.09925	0
30	21764	233.42	0.099008	0
45	23121	150.48	0.099527	0

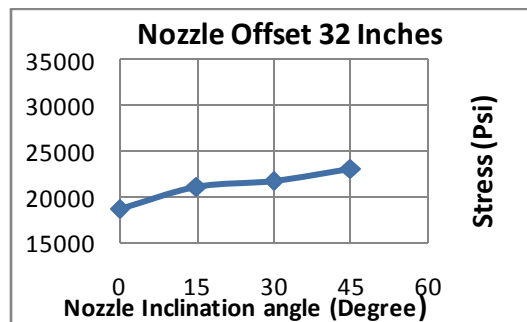

Figure 13 Von-mises Stress plot of Pressure vessel with nozzle at 32 inch offset

RESULT AND DISCUSSION:

RESULTS FOR PRESSURE VESSEL WITHOUT REINFORCEMENT:

Pressure vessel without reinforcement with different type of nozzle location, different offset distance and inclination angle are modeled and analyzed for same pressure loading and boundary conditions. The result of the effect of single parameter are tabulated and shown in graph form in previous work. The combine result of different factors is shown below.

Table 6 shows the maximum Von-mises stress value in psi for evaluation of the effect of inclination angle on offset distance of nozzle. It is found from result that minimum stress is achieved when inclination angle is 45° and offset distance is 32 inch. Von-mises stress plot in figure 6 shows the effect of different inclination angle on different offset distances. At 45 inclination angles stress is less for 0, 16 and 32 inch offset.

Table 6 Von-mises stress (psi) result summary of Pressure vessel without reinforcement for effect of inclination angle on offset distance

Offset (Inches)→	0	8	16	24	32
Inclination ↓					
0° Inclination	23586	27243	22132	26931	18645
15° Inclination	26263	23829	23042	26333	21107
30° Inclination	28644	21686	22745	24904	21764
45° Inclination	24308	23244	23320	25056	23121

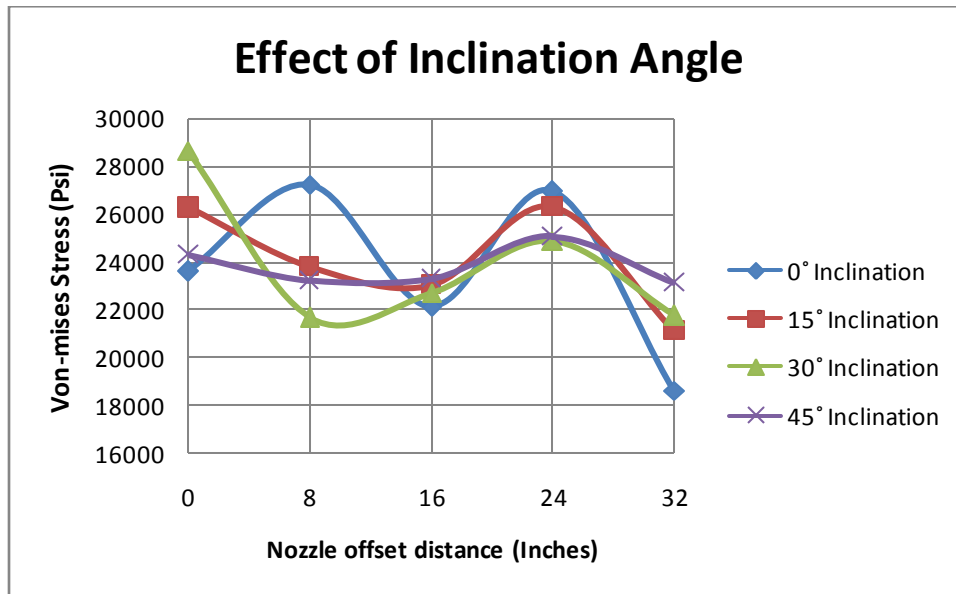

Figure 14 Von-mises Stress plot of Pressure vessel without reinforcement with nozzle offset at different inclination

Table 7 von-mises stress (psi) result summary of Pressure vessel without reinforcement for effect of offset distance on inclination angle

Inclination (Degree) →	0	15	30	45
Offset (Inches) ↓				
0 inches	23586	26263	28644	24308
8 inches	27243	23829	21686	23244
16 inches	22132	23042	22745	23320
24 inches	26931	26333	24904	25056
32 inches	18645	21107	21764	23121

It is found from result that minimum stress is achieved when offset distance is 32 inches and inclination angle is 0°. At 32 inches offset stress is minimum for most of the inclination angles and effect of inclination angle is also less for 16 and 24 inch offset.

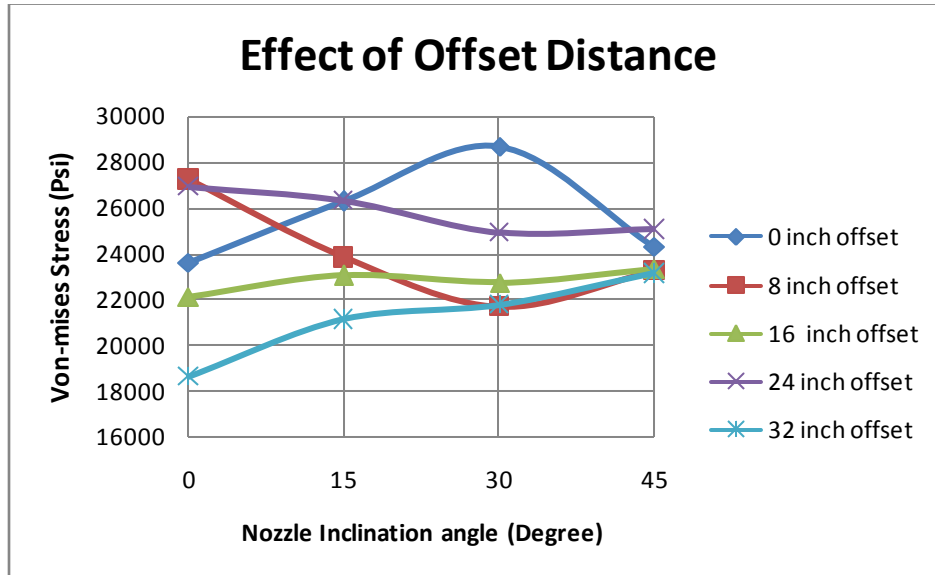

Figure 15 Von-mises Stress plot of Pressure vessel without reinforcement with inclination angle at different nozzle offset.

CONCLUSIONS:

- It is found that stress level is within the allowable stress in pressure vessel with reinforcement which is within the range of allowable stress in pressure vessel without reinforcement.
- Stress variation with change in inclination angle is less 24 inch and 32 inch offset.
- For pressure vessel without reinforcement minimum stress at 0 inch offset is at 0° inclination, at 8 inch offset is at 30° inclination, at 16 inch offset is at 0° inclination, at 24 inch offset is at 30° inclination, and at 32 inch offset is at 0° inclination.
- It is found from result that minimum Von-mises stress at nozzle is achieved when offset distance is 32 inches and inclination angle is 0° for pressure vessel without reinforcement

REFERENCES:

- [1] M. Jadav Hyder, M Asif, "Optimization of Location and Size of Opening In A Pressure Vessel Cylinder Using ANSYS". Engineering Failure Analysis .Pp 1-19, 2008.
- [2] Jorge R. Miranda, Carlos A, "Stress Analysis on Vessel/Nozzle Intersections With/Without Pad Reinforcement For Cylindrical Pressure Vessels", 19th International Congress Of Mechanical Engineering, November 2007, 5-9
- [3].Binesh P Vyas, R M Tayade, Design Of Vertical Pressure Vessel Using PVElite Software, International Journal Of Engineering Research And Technology, Vol. 2, Issue 3.
- [4]. Chattopadhyah S," pressure vessel design and practice", CRC press, 2005, pp. 78-79.
- [5]. Moss D R, "Pressure Vessel Design Handbook, third edition, Gulf professional publication, united state of America.

- [6]. ASME Boiler and Pressure Vessel Code, Section VIII, Division 1.
- [7]. A D Belegundu & T R Chandupatla, "Introduction to Finite Elements in Engineering", Prentice-Hall India Private Limited, Second edition 2000.
- [8]. Thaker H. R. ME thesis, "Design and Stress Analysis of a Reactor Using Finite Element Method" Gujarat University 2007.